



TRAINING OF TRAINERS (TOT) MANUAL FOR MASONS

ON DISASTER RESILIENT CONSTRUCTION TECHNIQUES

Supported by

UN HABITAT
FOR A BETTER URBAN FUTURE



*Empowered lives.
Resilient nations.*

The State of Kerala was heavily impacted due the fury of nature in August 2018. Between June 1 and August 18, 2018, the State experienced the worst ever floods in its history since 1924. During this period, the state received cumulative rainfall that was 42% excess of the normal average. The heaviest spell of rain was during 1-20 August, when the state received 771mm of rain. The torrential rains triggered several landslides and forced the release of excess water from 37 dams across the state, aggravating the flood impact. Nearly 341 landslides were reported from 10 districts. Idukki, the worst hit district, was ravaged by 143 landslides. The flood left majority of people homeless due to impact to their houses severely damaging to their habitation.

Following the severe floods, a Post Disaster Needs Assessment (PDNA) was jointly undertaken by government, United Nations and other development partners to assess the damage and loss to various critical infrastructures. The assessment thus identified housing as one of the most affected sectors along with agriculture and livelihoods as most critical sectors needed priority interventions in the post flood recovery phase.

In this backdrop, UNDP and UN-HABITAT jointly with the overall guidance and leadership of the Government of Kerala initiated a project on Shelter Recovery through establishment and strengthening of Shelter Hubs in three critically affected districts of Kerala. The project aimed at building back better (BBB) through providing training to masons and engineers through a training of trainers (TOT) programme to promote disaster resilient house construction practices in various districts of the state during the recovery phase along with ensuring risk informed construction practices.

This training manual has been developed to provide basic understanding, concepts and overall understanding of masons on

construction of disaster resilient housing. The ToT also includes both class room and hands on training of the masons at the community level to acquaint them on various construction designs and techniques needed to be incorporated during the training programme.

This manual will provide the much-needed tools, technologies and construction practices by adopting disaster resilient features to enable the houses to absorb future shocks.

UN-HABITAT is thankful to the Government of Kerala, UNDP and other partners involved in this process of development of the manual. It is expected that this manual would act as a guidance note for the engineers not only to undertake future training programmes but also spread the message of safer and disaster proofing houses in the state.

This manual has been developed through wider consultations, referring to various existing manuals in similar disaster situations and taking into consideration various house construction practices in the state. A consultant was hired to develop this manual through undertaking a training needs assessment (TNA) reviewing the damage and losses due to the floods and landslides in the state an considering the existing house construction practices in the state.

It is expected that this manual will of much help to masons who play a very critical role in house construction by adopting disaster resilient construction practices for sustainable reduction of disaster risks in the state of Kerala.

UN-HABITAT

Table of Contents

Training Agenda	6
Session 1: Introduction	8
1.1. Damage to housing sector in Kerala during floods.....	9
1.2. Effect of flood on various parts of building.....	11
Session 2: Brick Masonry Construction Techniques	12
2.1. Types of Foundations.....	13
2.2. Types of Beam Constructions.....	15
2.3 Types of Column Construction.....	16
2.4. Details of Structural Components.....	17
2.5. Step-wise construction of masonry buildings.....	22
Session 3: Bamboo Construction Techniques	25
3.1 Most suited species found in Kerala.....	26
3.2. Foundation.....	27
3.3. Floor.....	29
3.4. Wall.....	33
3.5. Roof.....	36

Table of Contents

Session 4: Retrofitting techniques	41
4.1 Common failures in a building during disaster.....	42
4.2 Retrofitting of failure in masonry buildings.....	43
4.3 Failure of soft-stories in RCC structures.....	43
4.4 Structural crack repair techniques.....	44
Session 5: Landslide Resistant Construction Techniques	45
5.1. Masonry wall.....	48
5.2. Gabion wall.....	49
5.3. Crib wall.....	50
5.4. Buttress wall.....	51
5.5. Cantilever wall.....	52
Session 6: Soil Piping	54
References.....	57

Annexure

1. Feedback Form.....	58
2. Training handouts – English.....	59

TRAINING AGENDA

Day 1

Time	Activity
09:00 am to 10:00 am	Registration and Introduction
10:00 am to 11:00 am	Elementary Presentation on various disasters and discussion on their experience during floods
11:00 am to 11:15 am	Tea
11:15 am to 12:00 am	Brick masonry construction techniques <ul style="list-style-type: none">•Types of foundation•Types of beam construction•Types of column construction•Details of structural components
12:00 pm to 01:00 pm	Landslide resistant construction techniques <ul style="list-style-type: none">•Retaining walls•Excavation methods
01:00 pm to 02:00 pm	Lunch
02:00 pm to 03:00 pm	Bamboo construction techniques <ul style="list-style-type: none">•Bamboo preservation techniques•Bamboo foundation•Bamboo flooring•Bamboo walls•Bamboo roofing
3:00 pm to 3:45 pm	Flood and landslide retrofitting techniques <ul style="list-style-type: none">•Common failures in a building during disaster

TRAINING AGENDA

	<ul style="list-style-type: none">•Retrofitting of failures in masonry buildings•Failure of soft-stories in RCC structures Structural crack repair techniques
03:45 pm to 04:00 pm	Tea

Day 2

Time	Activity
9:00 am to 10 am	Brief on hands on training
10:00 am to 11:00 am	Transfer to site
11:00 am to 01:00 pm	On-Site Training
01:00 pm to 02:00 pm	On-site lunch
02:00 pm to 03:30 pm	On-site training
03:30 pm to 04:00 pm	Transfer back to hotel
04:00 pm to 04:15 pm	Tea

Session Objective

- Various disasters, especially Kerala floods of 2018.
- Damages to housing sector in Kerala during flood
- Effect of flood on various parts of building.

Expected Outcome

Provide a better understanding on various disasters and vulnerabilities. Causes for building damages and parts of building that are more prone to damage during a disaster.

Mode of conducting training

- Presentation
- Q & A's

Materials Required

- Laptop
- Projector

1.1 Damage to housing sector in Kerala during floods

The main reasons for housing collapses in Kerala were: (i) high current of the floodwater; (ii) the inundation of the buildings for several days, causing differential settlement of the foundations; (iii) flash floods, especially where the buildings were too close to rivers and canals; and (iv) landslides.

Reasons for building failure

- Low plinth height (less than 600 mm) in flood-prone areas.
- Construction of foundation on soft soil leading to differential settlement.
- Failure of walls due to lack of bands and consequential failure of roods due to inundation.
- Due to poor construction and missing features mentioned in National Building Code.



SESSION 1: INTRODUCTION

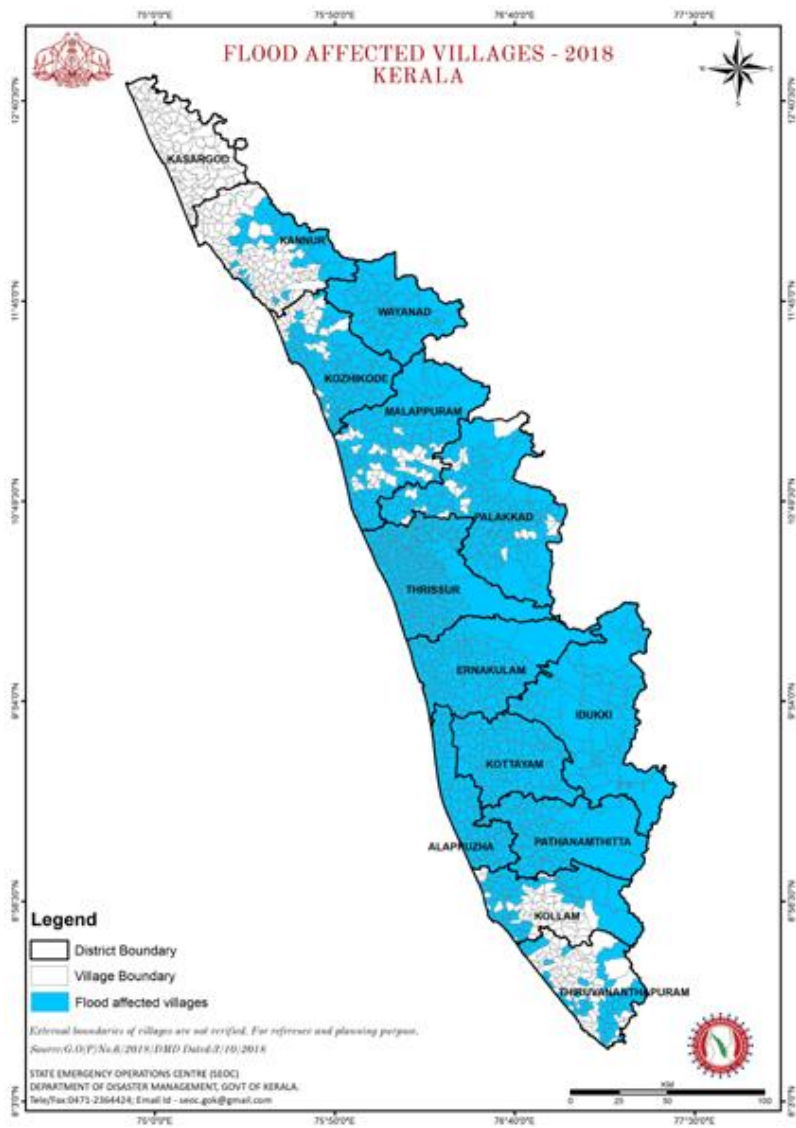

1.2. Effect of flood on various parts of buildings

Foundation

Foundations in case of pucca and semi-pucca houses are relatively durable, but in high-intensity flood, shallow foundations can become unstable due to scouring of soil-cover. Prolonged duration flood can lead to foundation settlement, thereby causing cracks and failures in different parts of the building. Houses with bamboo and sometimes timber posts embedded directly into the earthen plinth (found in tribal villages of Kerala) are extremely vulnerable and get damaged even in a low-intensity flood, thus requiring frequent maintenance.

Wall

Brick walls are relatively durable but can experience staining, peeling of plaster and weakening of mortar joints at lower ends if immersed in a flood of high depth and duration. Cracks may develop if settlement of foundation occurs. In the case of bamboo walls, during flood of high depth and moderate duration, the damage begins at the lower part of walls and hence weakening the walls and eventually resulting in complete damage.

Roof

RCC roof can withstand impact of heavy rainfall and wind, but can get weakened and may even collapse if foundation settles or walls are damaged. CI sheets Can lead to corrosion in contact with water and vulnerable to secondary hazard of heavy rainfall accompanying flood. Particularly vulnerable to strong wind – can crumple and get blown off, especially if connections to frame are inadequate.

Session Objective

The session on brick masonry construction techniques focuses on various construction techniques that need to be followed for the construction of disaster resilient buildings. The session covers all parts of the building from foundation to roof.

Expected Outcome

Equip masons with a better understanding on various disasters and vulnerabilities. Causes for building damages and parts of building that are more prone to damage during a disaster.

Mode of conducting training

- Presentation
- Q & A's

Materials Required

- Laptop
- Projector

SESSION 2: BRICK MASONRY CONSTRUCTION TECHNIQUES

This chapter covers disaster resilient construction techniques for brick masonry buildings. The common materials used for construction in Kerala are burnt bricks, cement concrete (CC) blocks and laterite (where it is available). The common materials used for roofing are RCC, Mangalore tiles and galvanised iron (GI) sheets. In many cases the buildings are constructed without considering the possible disaster risk due to various factors like cost reduction, for early completion, etc.

In this chapter methods to be adopted while constructing foundation, walls, reinforcement and other structural components are included are explained graphically with the specifications. Special focus has been given to the structural components that are require attention during building construction.

2.1 Foundation

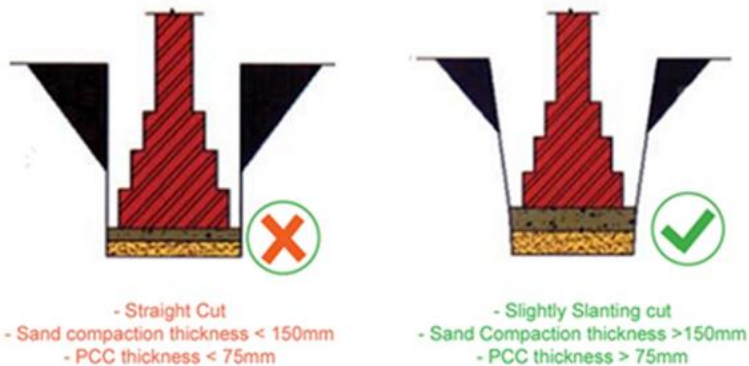

SESSION 2: BRICK MASONRY CONSTRUCTION TECHNIQUES

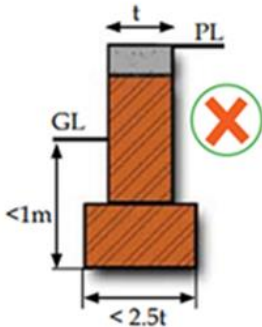

- Foundation width $< 2\frac{1}{2}$ times wall thickness
- Make a wall without foundation
- Use unbaked bricks in the foundation

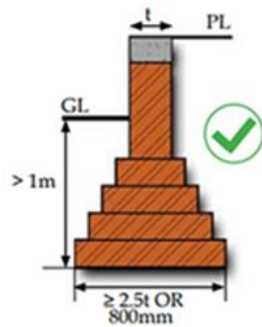

- Foundation width $> 2\frac{1}{2}$ times wall thickness or 0.8m, whichever is more
- Use baked bricks and stones
- Minimum depth = 1000 mm

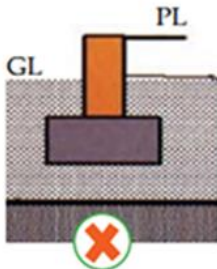

- Foundation on loose or soft soil

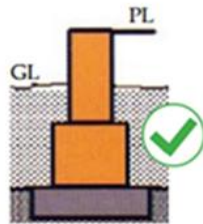

- Foundation on Hard Soil

This section shows the techniques to be adopted while construction the foundation. Common mistakes include quantity of materials used, foundation to wall thickness ratio and construction of foundation on soft soil. Solution to each of these are given above and need to be considered while constructing the foundation.

SESSION 2: BRICK MASONRY CONSTRUCTION TECHNIQUES

2.2 Beam

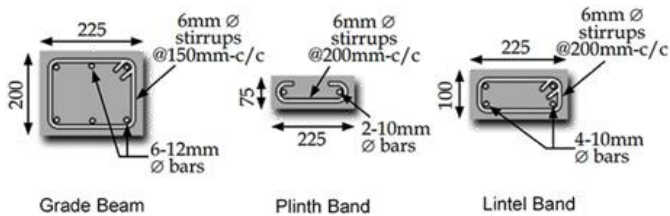
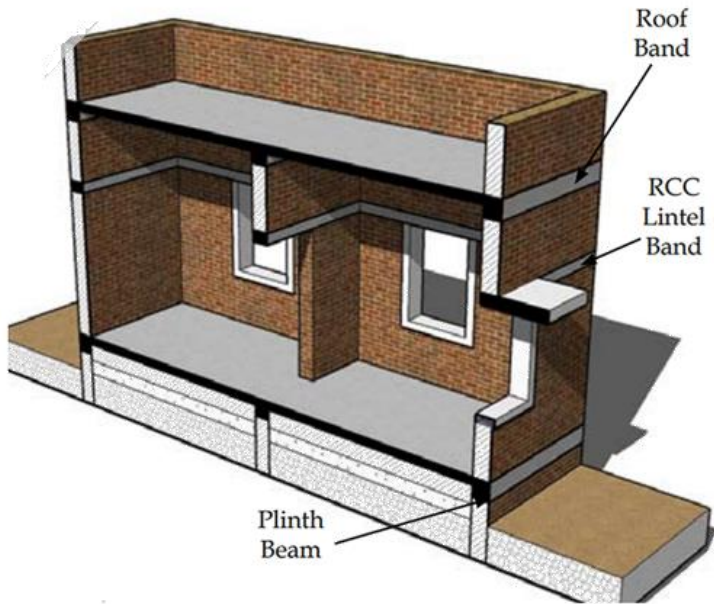

This section shows the construction of various types of beams. Beams play a major role in strength of the building and should be constructed with the above-mentioned specifications.

SESSION 2: BRICK MASONRY CONSTRUCTION TECHNIQUES

2.3 Column



- Inadequate Stirrup Details

- Bend the Stirrup through 135°

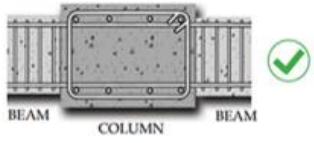
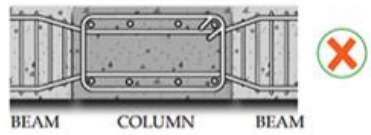

- Beam bars bent in joint region (overstress the core concrete adjoining the bends)

- Straight beam bars

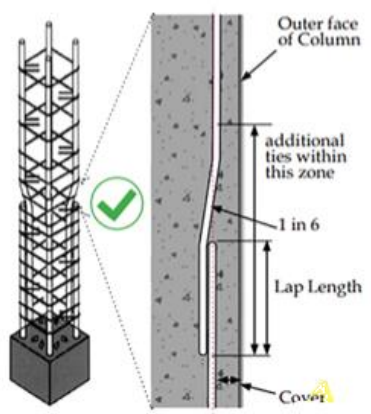
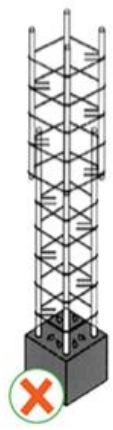

- Insufficient Lap Length

- Adequate Lap Length with slope of 1:6

This section shows the construction of columns. Specifications for various types of stirrups, beam-column joints and lap length of reinforcements are described.

SESSION 2: BRICK MASONRY CONSTRUCTION TECHNIQUES

2.4 Details of structural components

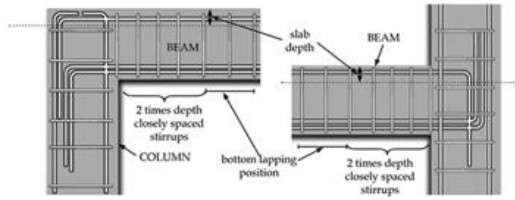

Reinforcement Detail of Beam-Column Joint at Roof Level

Reinforcement Detail of Beam-Column Joint at Floor Level

RCC BAND DETAILS

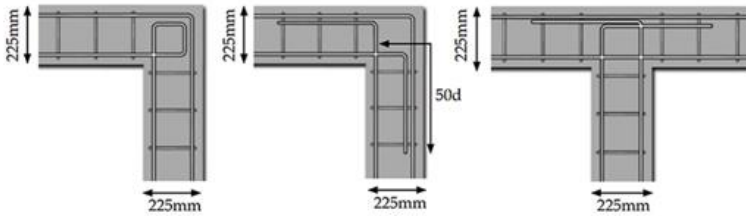

L-junction Plan

L-junction (alternative) Plan

T-junction Plan

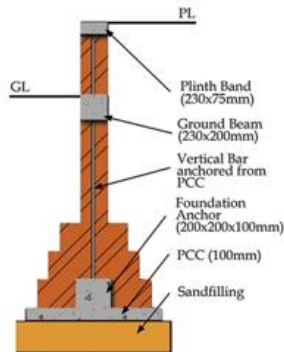

This section shows the construction of structural elements like construction of L and T-joints, and also the vertical reinforcement connecting the foundation to roof.

SESSION 2: BRICK MASONRY CONSTRUCTION TECHNIQUES



- Too High Walls



- Average wall height should be 2700 to 3000mm



- Too high walls
- Long unsupported walls



- Wall length < 8 times the thickness
- Addition of a buttress wall reduces L/H Ratio

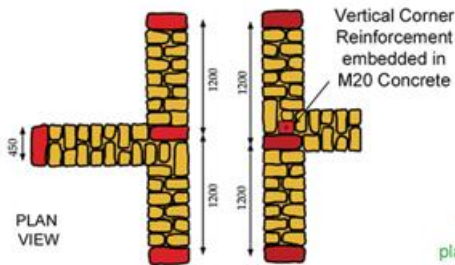

Through stone should be placed horizontally at a minimum spacing of 1200mm center-to-center

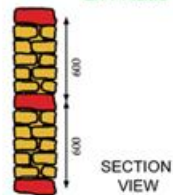

Through stone should be placed vertically at a minimum spacing of 600mm

This section shows the specifications for wall height, thickness and placement of through stone.

SESSION 2: BRICK MASONRY CONSTRUCTION TECHNIQUES



- Openings too close to corners



- Openings well away from the corners

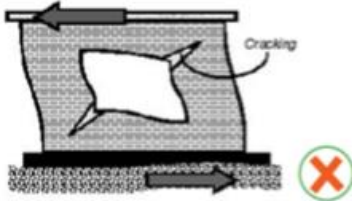

- Diagonal Cracking in building with no Corner Reinforcement

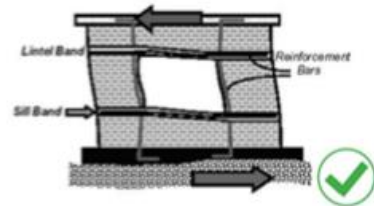

- No Cracks in Buildings with Vertical Reinforcement



- Too many unreinforced openings
(minimum distance between unreinforced openings should be 600mm)

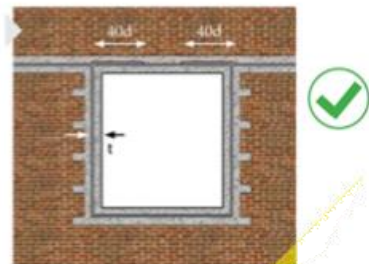

- Openings with Reinforced Band all around

This section shows the placement of openings and placement of reinforcements around the opening to avoid cracking during a disaster.

SESSION 2: BRICK MASONRY CONSTRUCTION TECHNIQUES

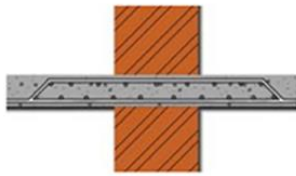

- RCC Slab at the support should be reinforced at both top and bottom

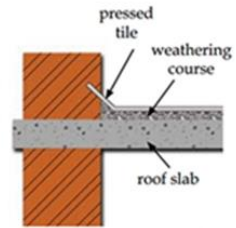

-Proper weathering course with pressed tile layer to protect RCC Slab

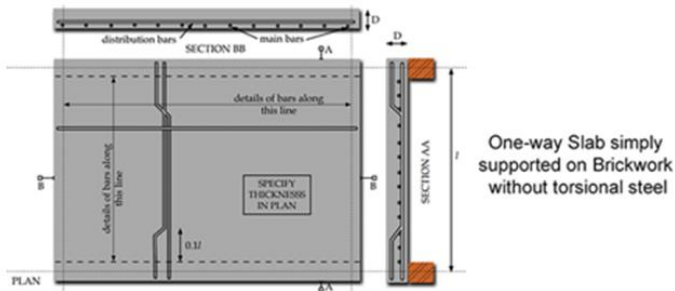
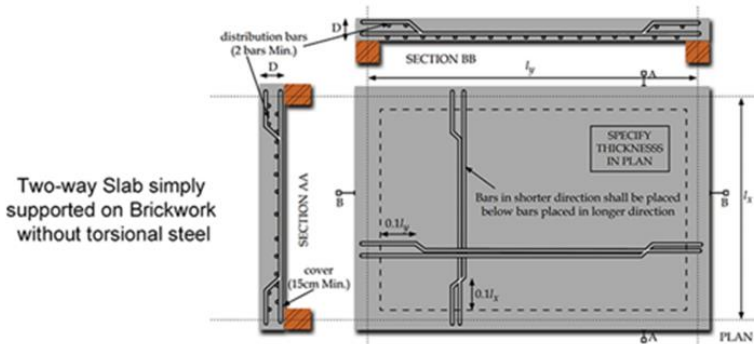

This section shows the construction of one-way and two-way slab without torsional steel along the with the placement of RCC slabs.

SESSION 2: BRICK MASONRY CONSTRUCTION TECHNIQUES

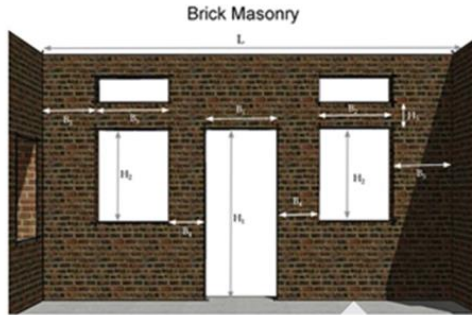

$B1+B2+B3$
 $\leq 0.5L$ (for One Storey)
 $\leq 0.42L$ (for Two Storey)
 $\leq 0.33L$ (for Three storey)

$- [600\text{mm} \leq B4 \leq 0.5H2]$
 $- [600\text{mm} \leq B5 \leq 0.25H1]$
 $- [H3 \leq 600\text{mm or } 0.5(B2 \text{ or } B3)]$

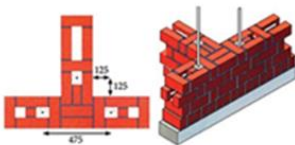

Rat-trap Bond (T-Joint)

- Vertical Rod should be placed at 125mm from the inner face of the Brickwork

- Vertical Rod should be placed at 245mm from the inner face of the Brickwork

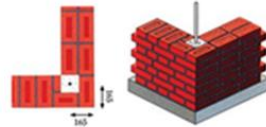

English Bond (L-Joint)

- Locate the vertical bar at 165 mm from the outer face of 230 mm wall

Rat-trap Bond (L-Joint)

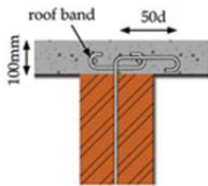
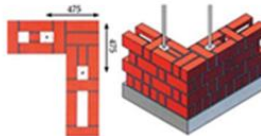

- Roof band should be provided within the roof-slab

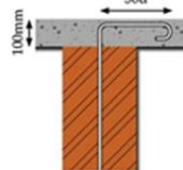

- Anchor the vertical tie into the roof slab

This section shows the specifications for vertical reinforcements and its connection with the roof band.

2.5 Step - wise construction of masonry buildings

Step 1

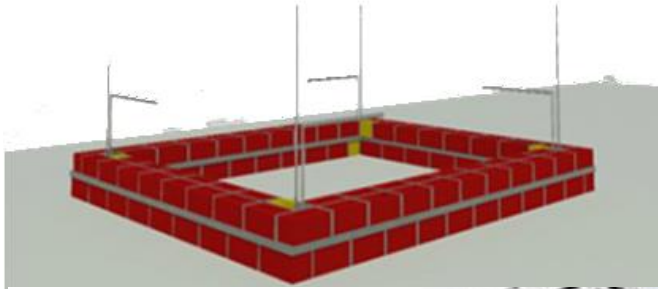

Vertical Reinforcement

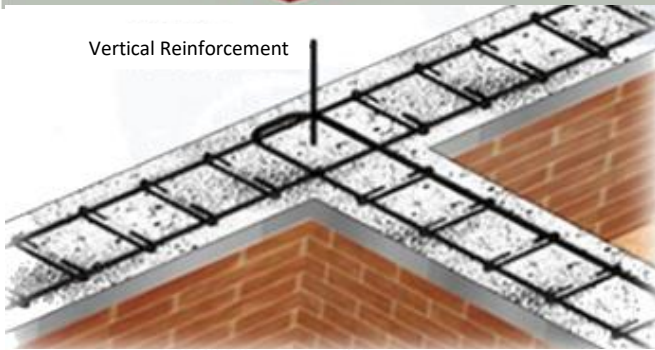

Vertical Reinforcement

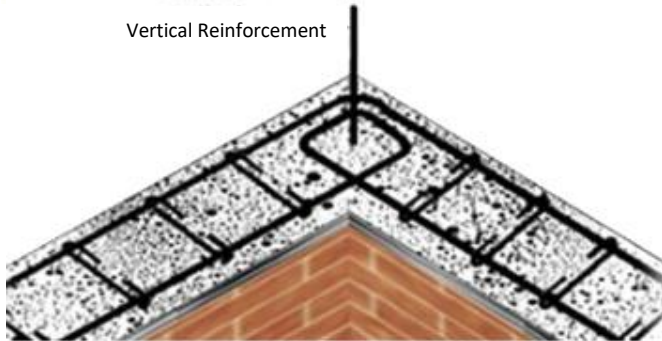

Step 1 shows the placement of reinforcement at plinth level. The vertical reinforcements should rise from the foundation. The second and third image shows the T-joint, L-joint and placement of vertical reinforcement

Step 2

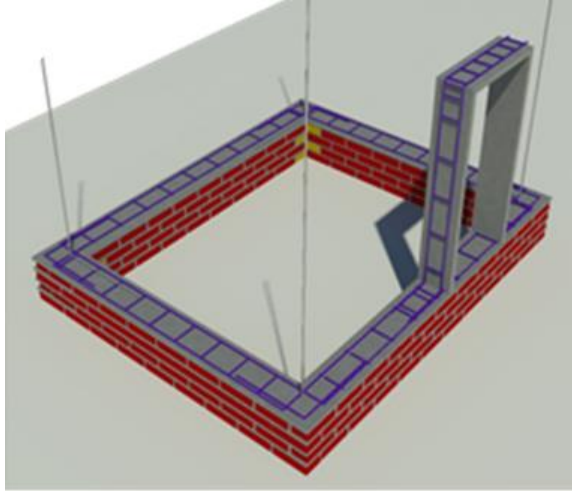

Step 3

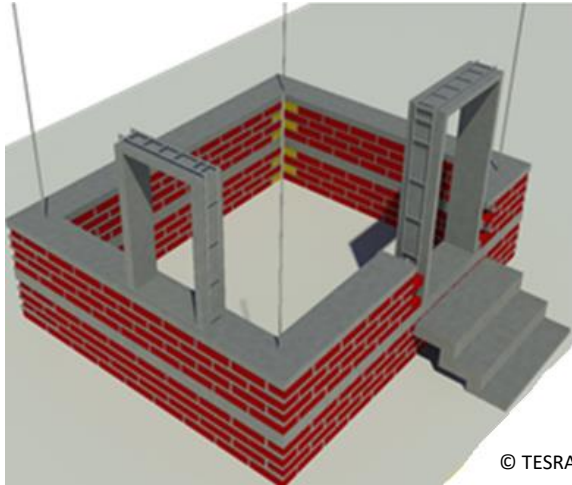

© TESRA

Step 2 shows the construction of plinth band and step 3 shows the construction of sill level band. Reinforcement bars should be placed along sill band (discontinuous at door openings).

SESSION 2: BRICK MASONRY CONSTRUCTION TECHNIQUES

Step 4

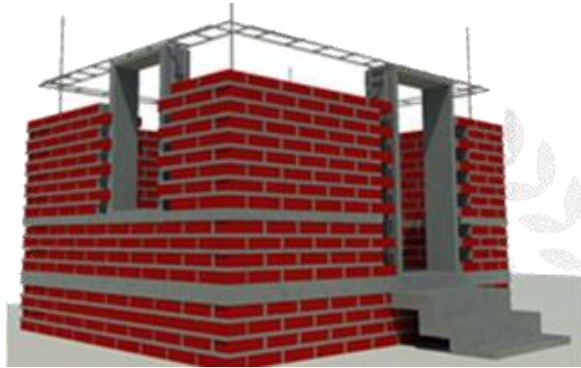

Step 5

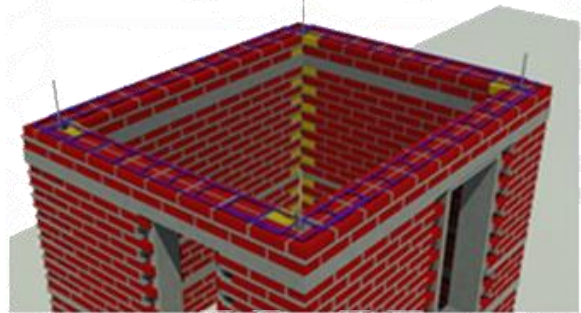

Step 6

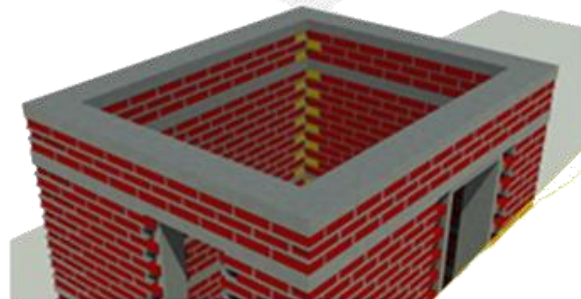

Step 4 shows the construction of lintel level band. Step 5 and 6 shows the construction of roof band. It should be noted that the vertical reinforcements are connected to the roof band and roof is built over it. Flat

CHNIQUES

Session Objective

- Advantage and disadvantages of bamboo structures
- Bamboo preservation techniques
- Disaster resilient construction practices using bamboo which includes foundation, flooring, walls, trusses and roof covering.

Expected Outcome

Enhance the knowledge on masons on construction techniques using bamboo. Promote use of bamboo in their upcoming projects.

Mode of conducting training

- Presentation
- Q & A's

Materials Required

- Laptop
- Projector

Bamboo is one of the oldest and most versatile building materials with many applications in the field of construction, particularly in developing countries. It is strong and lightweight and can often be used without processing or finishing. Bamboo building are mostly found in tribal villages of Kerala. In view of its rapid growth (exceeding most fast-growing woods), a ready adaptability to most climatic and edaphic conditions and properties superior to most juvenile fast-growing wood, bamboo emerges as a very suitable alternative. There are six species of bamboo available in homesteads including reed of which *Bambusa bambos* is the dominant species, accounting for 96 per cent. This is followed by *Bambusa vulgaris* and reed, constituting 2.23 per cent and 1.38 per cent respectively.

In spite of these advantages, the use of bamboo has been largely restricted to temporary structures and lower grade buildings due to limited natural durability, difficulties in jointing, a lack of structural design data and exclusion from building codes. This section covers various construction techniques using bamboo.

3.1 Most suited species found in Kerala

	Bambusa Bambos	Dendrocalamus Strictus
	Brighter shiny, green when fresh, yellow with age	Pale blue green when fresh dull green to yellow with age
Height	15-30m	8-16m
Diameter	Upto 150 mm	25-80 mm
Internodes	200-400 mm	300-400 mm
Thickness	Thick walled	Thick walled often solid

3.2 Bamboo Foundation

The types of bamboo foundation identified are:

- Bamboo in direct ground contact
- Bamboo on rock or preformed concrete footings
- Bamboo incorporated into concrete footings
- Composite bamboo/concrete columns
- Bamboo reinforced concrete
- Bamboo piles

Bamboo in direct ground contact

Bamboo, either on the surface or buried, can decay within six months to two years. Preservative treatment is therefore recommended together.

Bamboo on rock or preformed concrete footings

Ideally, where bamboo is being used for bearings it should be placed out of ground contact on footings of either rock or preformed concrete.

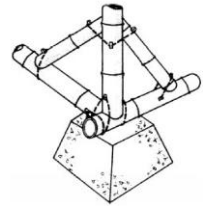

Bamboo incorporated concrete footings

The third approach is to incorporate the bamboo directly into the concrete footing. This can take the form of single posts or strip footings.

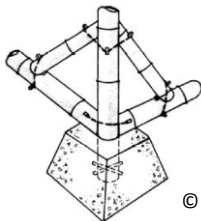

© INBAR

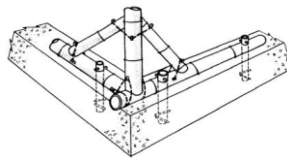

© INBAR

SESSION 3: BAMBOO CONSTRUCTION TECHNIQUES

Composite bamboo/concrete columns

An innovative development involves the casting of a concrete extension to a bamboo post using a plastic tube of the same diameter. The result is a bamboo post with an integral, durable foundation

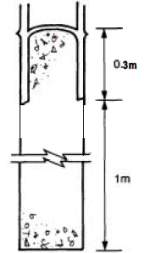

© INBAR

Bamboo reinforced concrete

Bamboo reinforced concrete slabs offer another solution, although this type of construction has its own specific problems

Bamboo piles

Bamboo piles have been used successfully to stabilize soft soils and reduce building settlement. In the example cited, treated split bamboo piles 8m long and 80 to 90mm in diameter were filled with coconut coir strands wrapped with jute. The sections were then tied with wire. After installation of the piles at 2m centers by drop hammer, the area was covered with a 2.5m surcharge of sandy material

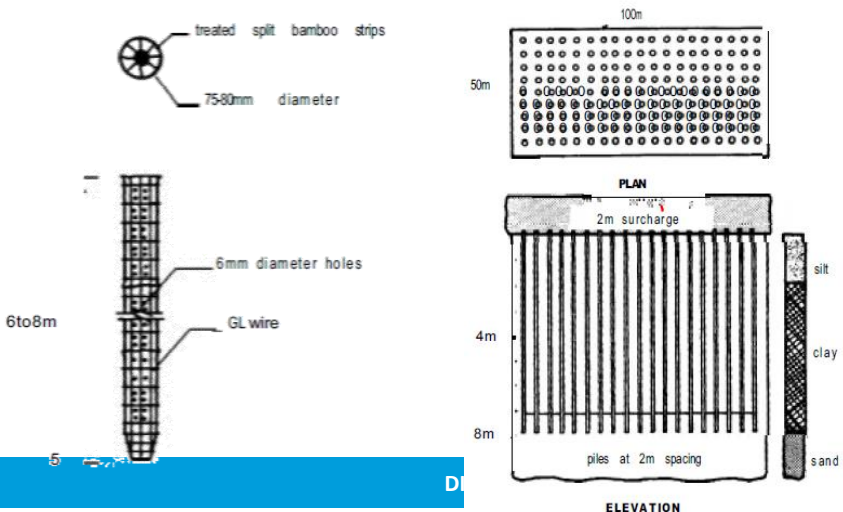

3.3 Bamboo Floor

The floor of a bamboo building may be at ground level, and therefore consist only of compacted earth, with or without a covering of bamboo matting. However, the preferred solution is to raise the floor above the ground creating a stilt type of construction. This improves comfort and hygiene and can provide a covered storage area below the floor. A minimum ground to floor distance of 500mm is recommended to allow for inspection (Janssen, 1995). When the floor is elevated, it becomes an integral part of the structural framework of the building.

The floor will comprise:

- Structural bamboo elements
- Bamboo decking

Floor structure

Floors normally consist of bamboo beams fixed to strip footings or to foundation posts. The beams therefore run around the perimeter of the building. Where the beams are fixed to posts, careful attention to jointing is required. Beams and columns are generally around 100mm in diameter.

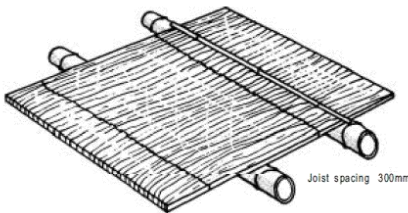

Joist arrangement –
primaries only

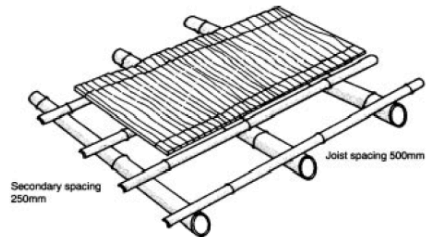

Joist arrangement –
primaries and secondaries

SESSION 3: BAMBOO CONSTRUCTION TECHNIQUES

Floor decking Bamboo floor decking can take one of the following forms:

- Small bamboo culms
- Split bamboo
- Flattened bamboo (bamboo boards)
- Bamboo mats
- Bamboo panels
- Bamboo parquettes

Small bamboo culms:

Small diameter culms are tied or nailed directly to the joists

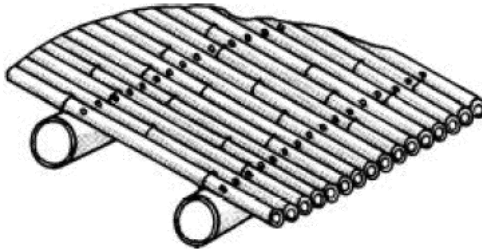

Split bamboo: bamboo culms are split along their length into strips several centimeters wide. They can be fixed directly to the joists in the case of tying or nailing, or a timber batten can be fixed to the joist beforehand to facilitate nailing.

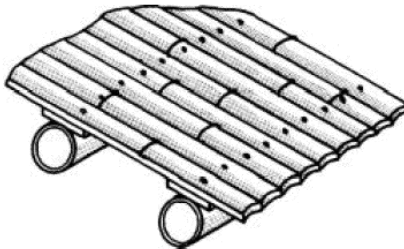

SESSION 3: BAMBOO CONSTRUCTION TECHNIQUES

Flattened bamboo (bamboo boards): These are formed by splitting green bamboo culms, removing the diaphragms then unrolling and flattening them. The resulting board is laid across the joists and fixed by nailing or tying. The surface finish of these three types of floor deck is, understandably, uneven and difficult to clean. They can be screeded with cement mortar for reasons of hygiene and comfort.

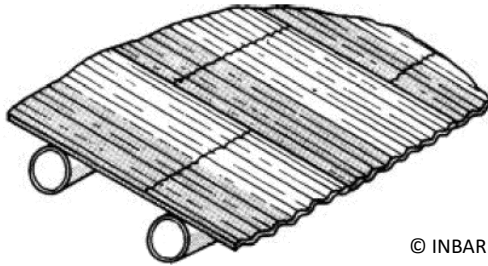

© INBAR

Bamboo mats: These are formed by weaving thin strips of bamboo. Strips vary in size from 20 x 2mm to 2 x 1 mm, depending on the intricacy of the pattern.

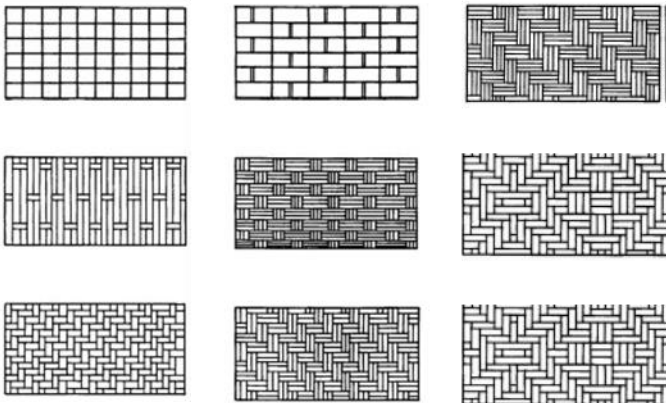

SESSION 3: BAMBOO CONSTRUCTION TECHNIQUES

Mats should not be fixed by direct nailing, but are held in place by bamboo strips or timber battens tied or nailed over the top. This is one of the easiest types of traditional floor to keep clean.

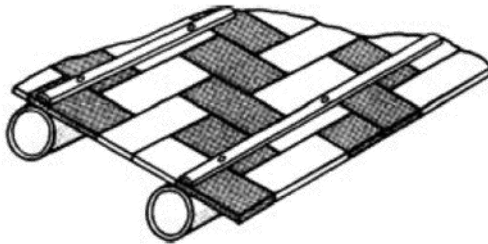

© INRAR

Bamboo panels:

Layers of woven mats or strips, laid at right angles, are bonded together into boards, which are then nailed to the joists.

Bamboo panels:

Layers of woven mats or strips, laid at right angles, are bonded together into boards, which are then nailed to the joists.

SESSION 3: BAMBOO CONSTRUCTION TECHNIQUES

3.4 Bamboo Wall

The most extensive use of bamboo in construction is for walls and partitions. The major elements of a bamboo wall (posts and beams) generally constitute part of the structural framework. As such they are required to carry the self-weight of the building and also loadings imposed by the occupants, the weather and, occasionally, earthquakes. To this end, efficient and adequate jointing is of primary importance.

Type of infill

- Whole or halved vertical or horizontal bamboo culms, with or without bamboo mats
- Split or flattened bamboo, with mats and/or plaster
- Bajareque
- Wattle (wattle and daub, lath and plaster, quincha)
- Woven bamboo, with or without plaster
- Bam boo panels

Whole or halved bamboo culms

The preferred orientation is vertical as this increases the shear resistance of the wall and is also better for drying after rain. Vertical members can be driven directly into the ground or fixed back to beams by tying with or without facing battens. Halved culms can be fixed in the same way, either as a single or double ply construction, or anchored between horizontal halved culms.

Woven bamboo mats can be attached to one or both faces using tied or nailed bamboo battens

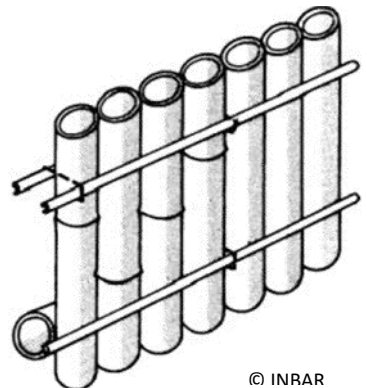

© INRAR

SESSION 3: BAMBOO CONSTRUCTION TECHNIQUES

Split or flattened bamboo

Can be fixed vertically to intermediate bamboo members tied to or mortised into the posts, or fixed horizontally directly to the posts. Boards can be stretched or covered by wire mesh to provide a suitable surface for plastering. Closely woven matting can also be applied to the board surface, with or without plaster.

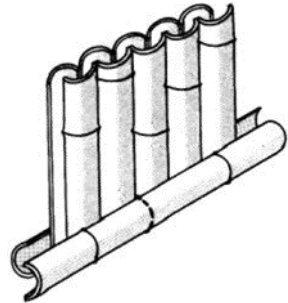

Bajareque

It consists of horizontal bamboo strips tied or nailed to both sides of the posts. The cavity is then filled with mud or mud and stones, producing a relatively massive form of construction.

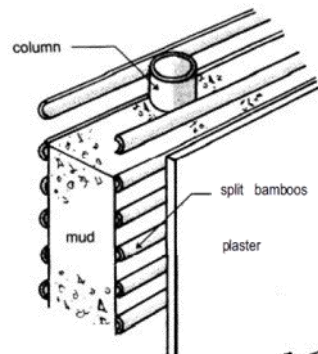

Wattle

Common in parts of India, Peru and Chile, this comprises coarsely woven panels of bamboo strips (vertical weft and horizontal warp), plastered on both sides.

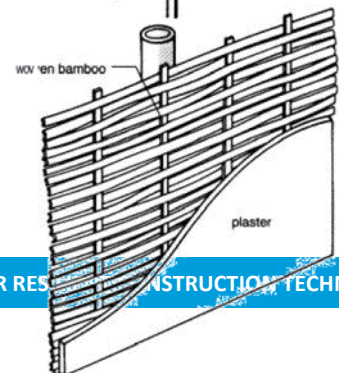

SESSION 3: BAMBOO CONSTRUCTION TECHNIQUES

Woven bamboo

Coarsely woven panels similar to those for wattle but with closer wefts can be used with or without plaster. The plaster can be made from any combination of mud, clay, and sand, stabilized with lime, cow dung, cement and organic fibers. The surface can be finished

with a lime wash to give a typical stucco appearance. Preservatives may be added but due attention should be paid to health, safety and environmental matters.

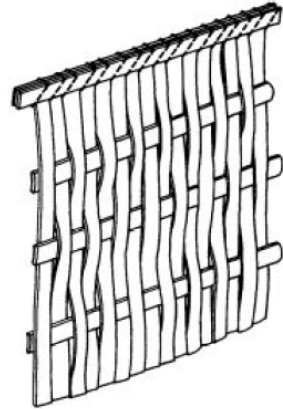

Woven bamboo wall construction

Bamboo panels

Panels have been developed specifically for use in walls and partitions and have the advantage of imparting greater structural rigidity to the construction.

Bamboo has also been used as a reinforcement for stabilized or rammed mud walls. However, difficulties exist in achieving an adequate bond between the mud and bamboo to ensure composite action.

3.5 Bamboo Roof

The roof of a building is arguably its most important component - this is what defines a construction as a shelter. As such, it is required to offer protection against extremes of weather including rain, sun and wind, and to provide clear, usable space beneath its canopy. Above all, it must be strong enough to resist the considerable forces generated by wind and roof coverings. In this respect bamboo is ideal as a roofing material - it is strong, resilient and light-weight.

The bamboo structure of a roof can comprise “cut” components - purlins, rafters and laths or battens, or triangulated (trussed) assemblies. Bamboo, in a variety of forms, is also used as a roof covering and for ceilings.

The simplest form of roof comprises a bamboo ridge purlin and eaves beams, supported on the perimeter posts. Halved culms are then laid convex side down, edge to edge, spanning from the ridge to the eaves. A second layer, convex side up, is then laid to cover the joints. The maximum overall span using this method is about 3 metres. A variation on this is the use of whole culms, suitably spaced to accept battens for tiles or thatch. To extend the span, a central post can be used.

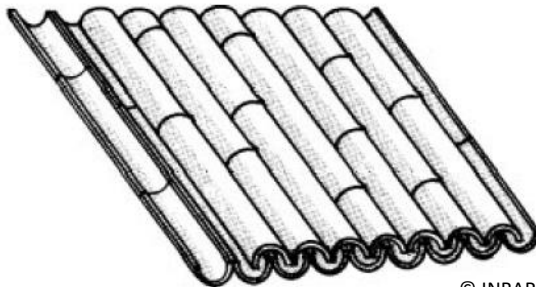

© INBAR

SESSION 3: BAMBOO CONSTRUCTION TECHNIQUES

Trusses: Trusses offer a number of advantages over traditional forms of construction, including more economic and efficient use of materials, the ability to span larger distances, the use of shorter components (counteracting effects of bow, crook and taper) and the use of prefabrication.

Much research and development has been carried out in this area. This work has highlighted the relative weakness of the joints and also of the bamboo in compression perpendicular to its length. In addition, much of the deflection of a loaded truss has been found to be due to

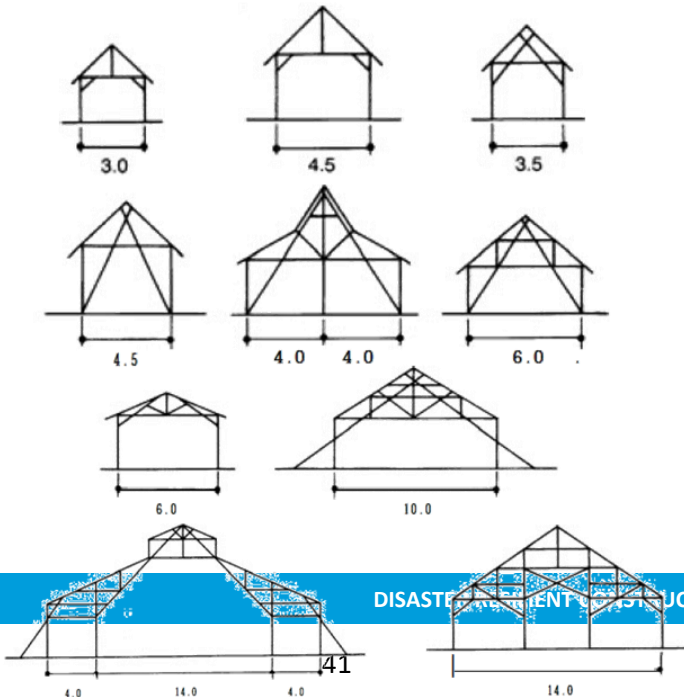

SESSION 3: BAMBOO CONSTRUCTION TECHNIQUES

The King-post and Fink are the simplest, readily spanning 4m using traditional jointing. Culm diameters typically range from 40-100 mm. Janssen has achieved an 8m span using improved jointing

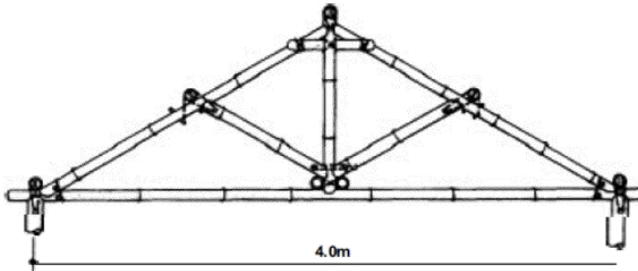

King-post truss

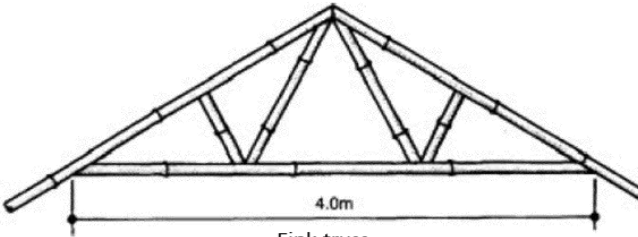

Fink truss

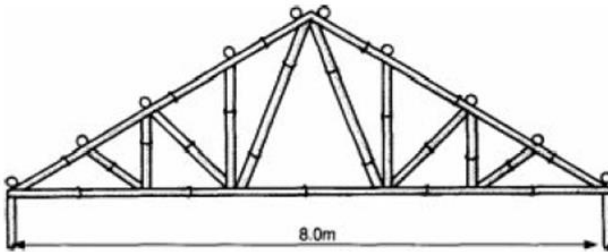

Janssen truss configuration

SESSION 3: BAMBOO CONSTRUCTION TECHNIQUES

© INBAR

Roof covering: Bamboo roof coverings can form an integral part of the structure, as in the case of overlapping halved culms. More often, they are non-structural in function. Examples include:

- Bamboo tiles
- Bamboo shingles
- Bamboo mats
- Corrugated bamboo roofing sheets
- Plastered bamboo

Bamboo tiles: these can take the form of halved, internodal culm sections, fixed to battens and overlapped in a similar manner to the full-length halved culms. Roofs covered in this manner are susceptible to leakage.

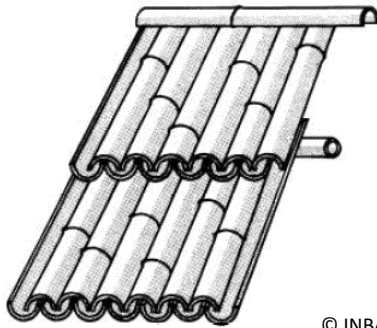

© INBAR

Corrugated bamboo roofing sheets: PF resin is applied to a bamboo mats to form a five-layer set which is then hot pressed between corrugated platens. UF resin bonded sheets overlaid with PF resin impregnated paper have also been produced. These products are strong and lightweight with good insulation properties.

Plastered bamboo: a cement plaster, with or without the addition of organic fibres, is traditionally applied to bamboo roofs.

SESSION 3: BAMBOO CONSTRUCTION TECHNIQUES

Bamboo shingles: shingles, measuring 30-40mm wide x internodal length (400-600mm) are cut from green culms, 70mm or more in diameter and then air dried. The shingles are hooked onto bamboo battens by means of a tongue cut into the underside. Three layers are required to make

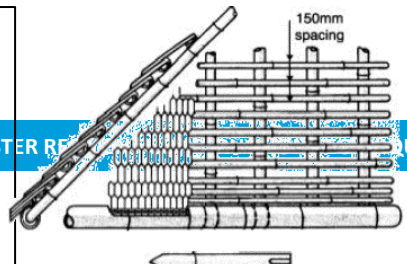

Bamboo mats: a layer of bitumen is sandwiched between two mats forming a semi-rigid panel. The mats can be fixed to rafters at 200-250mm centres. A bituminous or rubberized weatherproof coating is then applied to the finished roof

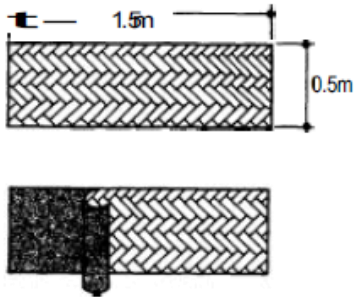

© INBAR

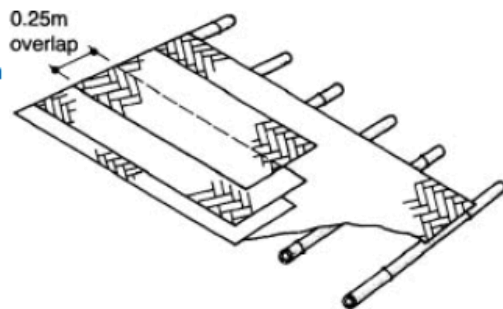

© INBAR

Session Objective

Session on retrofitting techniques focuses on various failures in building during and its retrofitting techniques. Training will be provided on both residential and public buildings.

Expected Outcome

Masons will have better understanding on repair and strengthening of building. This will be mostly applicable in case of partially damaged buildings.

Mode of conducting training

- Presentation
- Q & A's

Materials Required

- Laptop
- Projector
- White board
- Marker

4.1 Common failures in a building during disasters

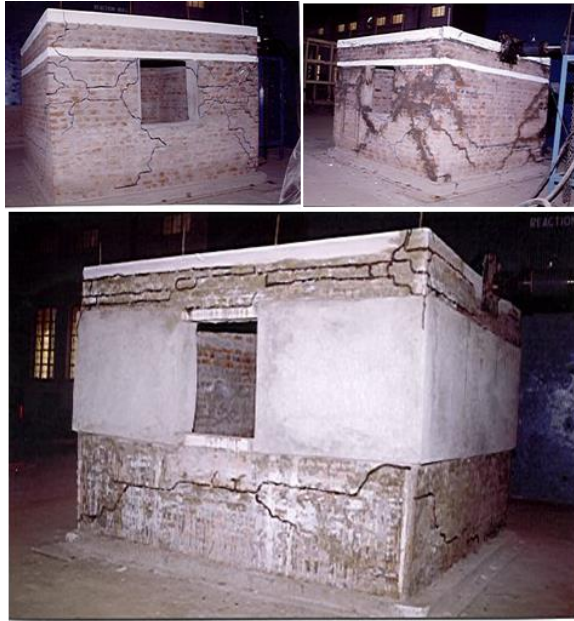

During a disaster cracks are initially formed at the corners and around the opening. Severe damages of these kind can lead to the collapse of the structure.



Retrofitting technique of column

4.2 Retrofitting of failure in masonry building

In order to retrofit the cracks, we need to introduce a band around the building as shown in the above image. Band consist of 10-gauge wire mesh and 1:3 cement plaster with 30 mm thickness and it will be applied both side of the wall and wire mesh is connected through-n-through by shear keys at 300 mm c/c.

4.3 Failure of soft-stories in RCC structure and its retrofitting

Soft-stories are most vulnerable part of the structure in multi stories most common failures is observed on soft-stories, there are several techniques of retrofitting of this type of buildings, like introduction of new column, shear wall, bracings etc. for detail refer following images:



Failure and collapse pattern

© TESRA

SESSION 4: RETROFITTING TECHNIQUES

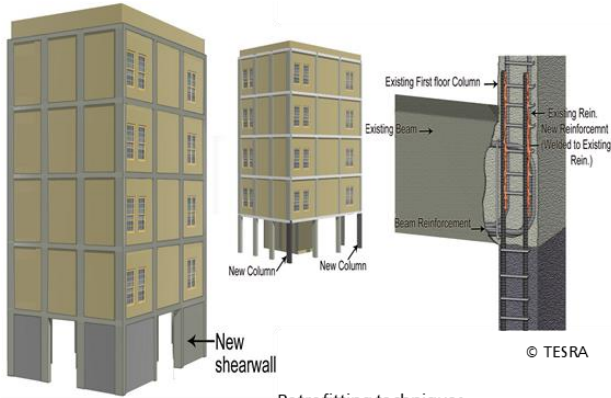

Retrofitting techniques

4.4 Structural crack repair techniques

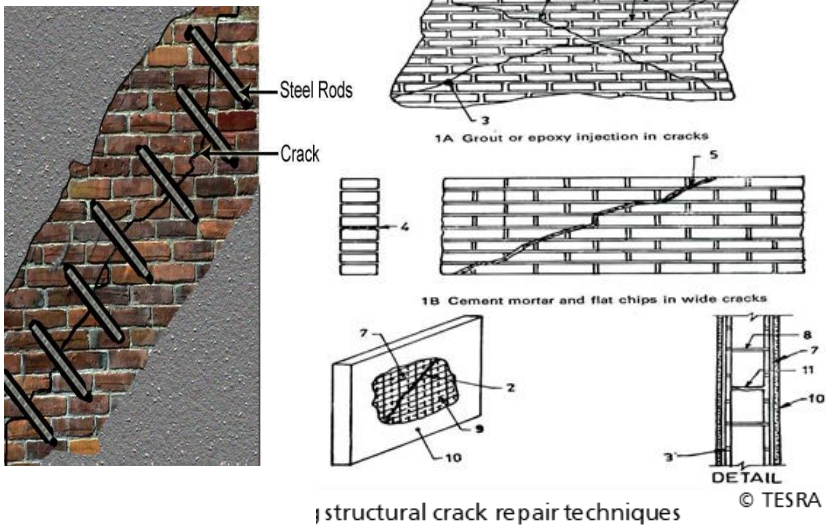

Structural crack repair techniques

Steel rods are connected perpendicular to the crack and welded. Holes are not drilled simultaneously as it can cause further damage to the wall.

Session Objective

The session on landslide hazard resilience focuses on landslide hazard vulnerability in Kerala and measures to control it. Training is given on construction of various kinds of retaining walls and excavation methods to prevent landslide.

Expected Outcome

Training will equip masons with a better understanding on various landslide resilience methods and site assessment.

Mode of conducting training

1. Presentation
2. Q & A's

Materials Required

1. Laptop
2. Projector

SESSION 5: LANDSLIDE HAZARD RESILIENCE

In Kerala, landslides commonly occur in localized areas of the Western Ghats region where the slope is steep and the soil is over saturated as a result of prolonged rainfall. These events vary from events affecting a parcel of land to those larger ones with much causality. Only the larger ones with losses of lives have been highlighted and studied in detail. The smaller events also indicate landslide potential of an area. most of the events are of debris flow type triggered by excess rainfall and are influenced by terrain factors like slope, overburden thickness, land use, relative relief, disposition of streams, landform at micro level etc.

Landslide prone area in each district				
District	Area (Km ²)	Area %	Area (Km ²)	Area %
	High		Low	
Pathanamthitta	170.28	6.41	426.25	16.04
Idukki	388.32	8.90	873.71	20.02
Wayanad	102.56	4.82	196.57	9.20



© Indian Express



© HDS

Landslides in Kerala (2018)

SESSION 5: LANDSLIDE HAZARD RESILIENCE

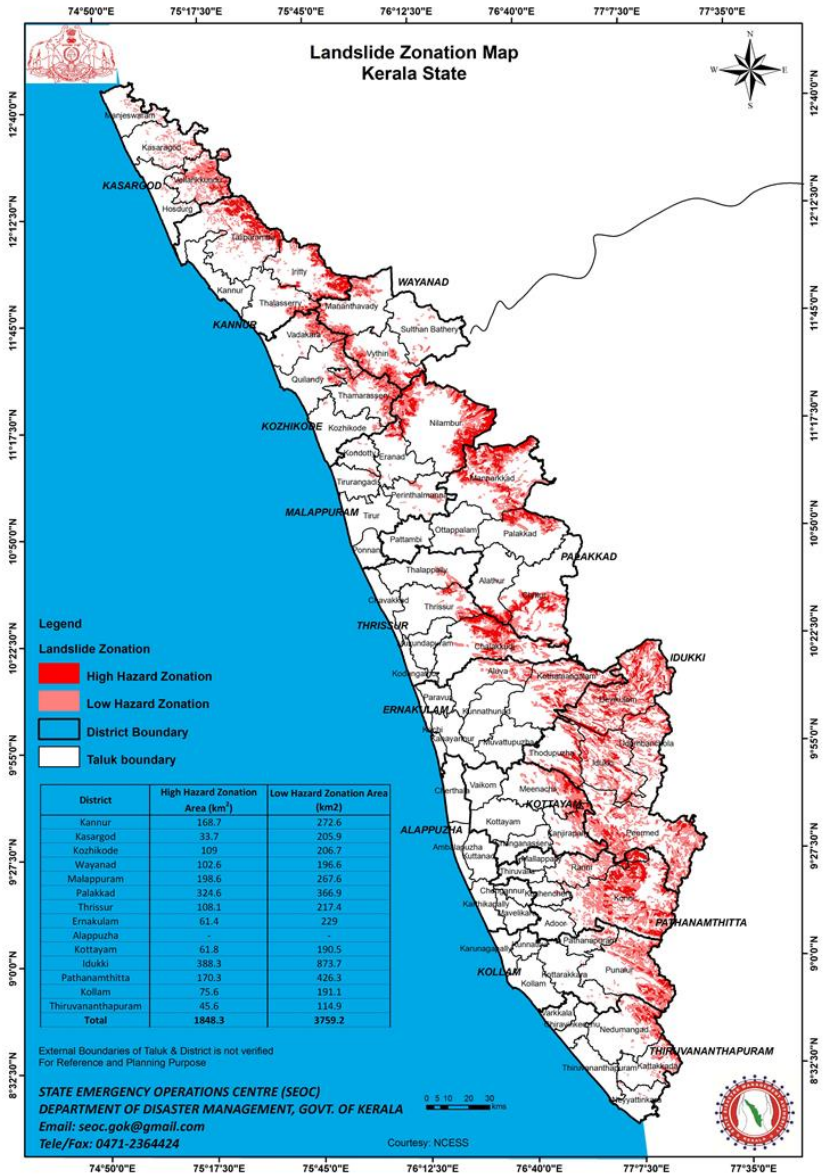

Types of retaining walls

5.1 Masonry wall

Retaining walls of upto four metres in height are constructed in random rubble-dry stone masonry. Retaining walls above four metres in height are built either in lime or cement mortar masonry or in dry stone masonry with 0.6 m wide mortar masonry bands three to four metres apart, laid both in horizontal and vertical directions.

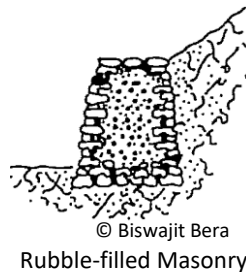
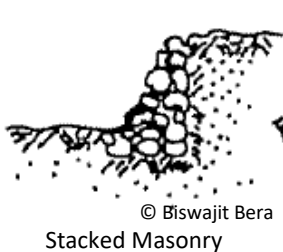
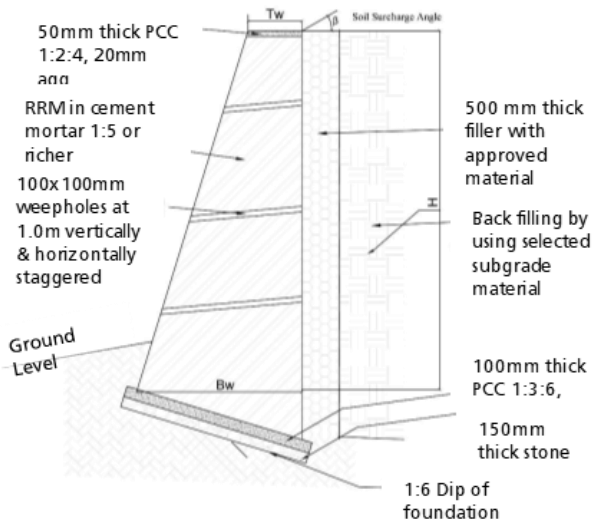

5.2. Gabion wall

Gabion Retaining walls are flexible structures which are very suitable in case of Tech 3 retaining structures for protection. It is also very effective for the protection near the water body, as the porosity of boulders will dissipate the wave energy effectively. Gabions are flexible in nature and can accommodate differential settlement very well.

- Flexible structure which can accommodate differential settlement.
- Free draining structure with no pore pressure development behind wall.
- Easy in construction, as it does not require skilled laborer.
- Does not require curing time as in case of R.C.C Retaining wall.
- Eco-friendly, as the vegetation growth over it, is compatible with surrounding environment.
- Used under full or partial submergence.
- Cost incurred is very less compared to R.C.C Retaining Wall and depends only on the local availability of boulders.

Maccaferri Gabion Mesh Type 1-x12, Wire Dia. 2.7/3.7mm, Zinc + PVC coated

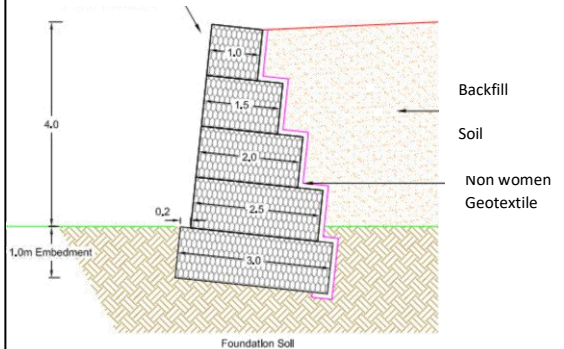

Cross-section of 4m high Gabion Retaining wall



Rock Filled Gabions

5.3 Crib Wall

- Timber walls or concrete crib walls and sausage walls are also used as retaining structures.
- A crib wall is made in a wooden mesh in which dry stone masonry is built.
- Sausage walls are made by forming sausages of steel wire netting of eight SWG with 10 cm square or hexagonal holes. The sausages are filled with hard local boulders / stones, and the wire-net is wrapped at the top.
- This process is carried out on the site where the sausage walls are to be installed.
- It has been found that sausage walls can withstand a greater amount of deformation than stone masonry, without cracking. They also allow free passage of water.



© Biswajit Bera

Timber or concrete crib wall

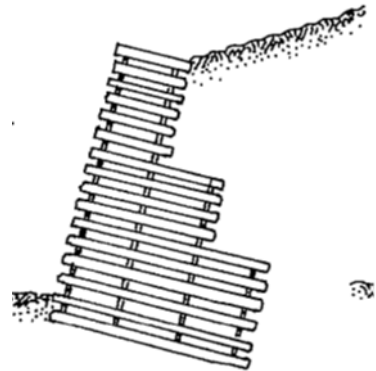

© Biswajit Bera

Multiple dept crib wall

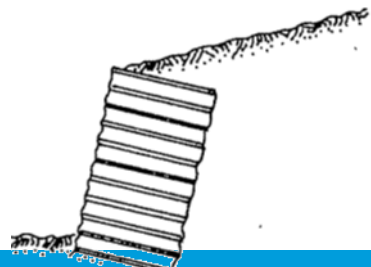

5.4 Buttress Wall

Buttresses are often used as retaining devices on landslides and creep movements on hill roads. Failure of the structure can take place due to foundation failure, shear between the structure and the foundation and shear through the structure itself. Therefore, rock buttresses are constructed, preferably on solid foundations, to avoid foundation failure. The buttress is constructed with the upper face vertical and the lower face with a slope of 1.5:1.

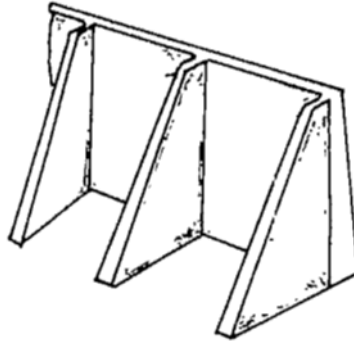

© Biswajit Bera

Concrete buttress wall or braced wall

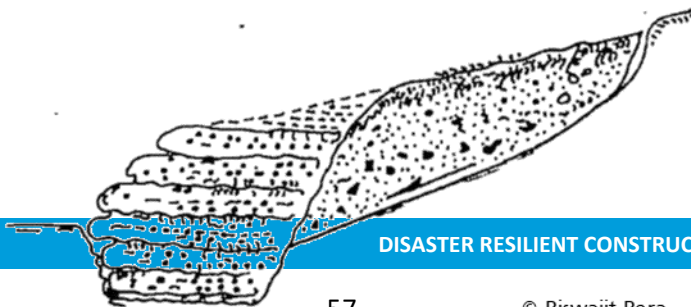

5.5 Cantilever Wall

Cantilever retaining walls are constructed of reinforced concrete. They consist of a relatively thin stem and a base slab. The base is also divided into two parts, the heel and toe. The heel is the part of the base under the backfill. The toe is the other part of the base.

- Use much less concrete than monolithic gravity walls, but require more design and careful construction.
- Generally economical up to about 25 ft. in height.
- Can be precast in a factory or formed on site.

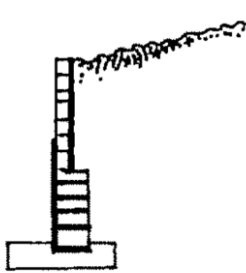

Masonry block

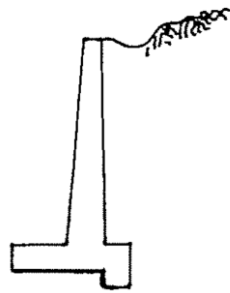

Reinforced concrete cantilever

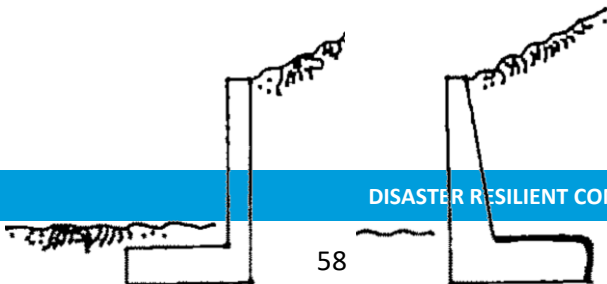

SESSION 5: LANDSLIDE HAZARD RESILIENCE

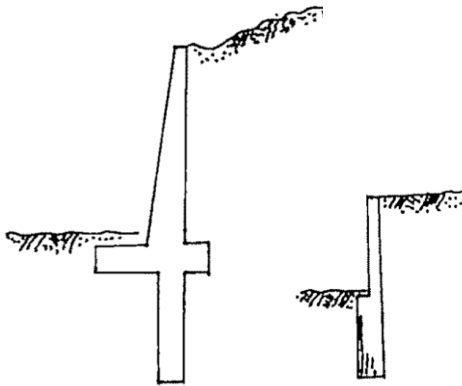

© Biswajit Bera

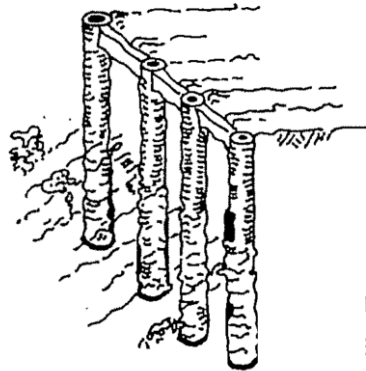

© Biswajit Bera

Pier supported reinforced concrete wall - cast-in-place reinforced concrete interconnecting grade beam

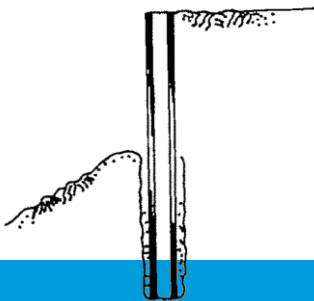

© Biswajit Bera

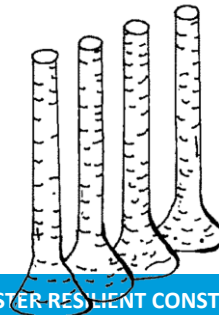

© Biswajit Bera

Steep H-pile wall - Cast-in-place caisson with interconnecting underream cones

Session Objective

Session on soil piping focuses on providing a brief understanding on land subsidence, tunnel formation etc and the problems caused by it.

Expected Outcome

Promote masons to consider soil piping vulnerability during site selection.

Mode of conducting training

1. Presentation
2. Q & A's

Materials Required

1. Laptop
2. Projector

The “Soil piping”, also known as tunnel erosion is the subsurface erosion of soil by percolating waters to produce pipe-like conduits below ground especially in non-lithified earth materials. Soil piping or “tunnel erosion” is the formation of subsurface tunnels due to subsurface soil erosion. Piping is an insidious and enigmatic process involving the hydraulic removal of subsurface soil causing the formation of an underground passage.

Land subsidence causes many problems including:

- Changes in elevation and slope streams, canals and drains
- Damage to bridges, roads, railroads, storm drains, sanitary sewers, canals, and levees
- Damage to private and public buildings
- Failure of well casings from forces generated by compaction of fine-grained material in aquifer systems.
- Permanent inundation of land, aggravates flooding, changes topographic gradients and ruptures the land surface.
- Reduces the capacity of aquifers to store water.

Soil piping indicate that this phenomenon occurs in many areas in the Western Ghats of the Kerala region. Many of piping are located at Idukki and Kannur, Kasaragod and then followed by Kozhikode, Palakkad, Ernakulam, Pathanamthitta, and Wayanad.



© NDMA

SESSION 6: SOIL PIPING IN KERALA

Land subsidence

Tunnel formation

Outlet of a pipe

Soil piping effects

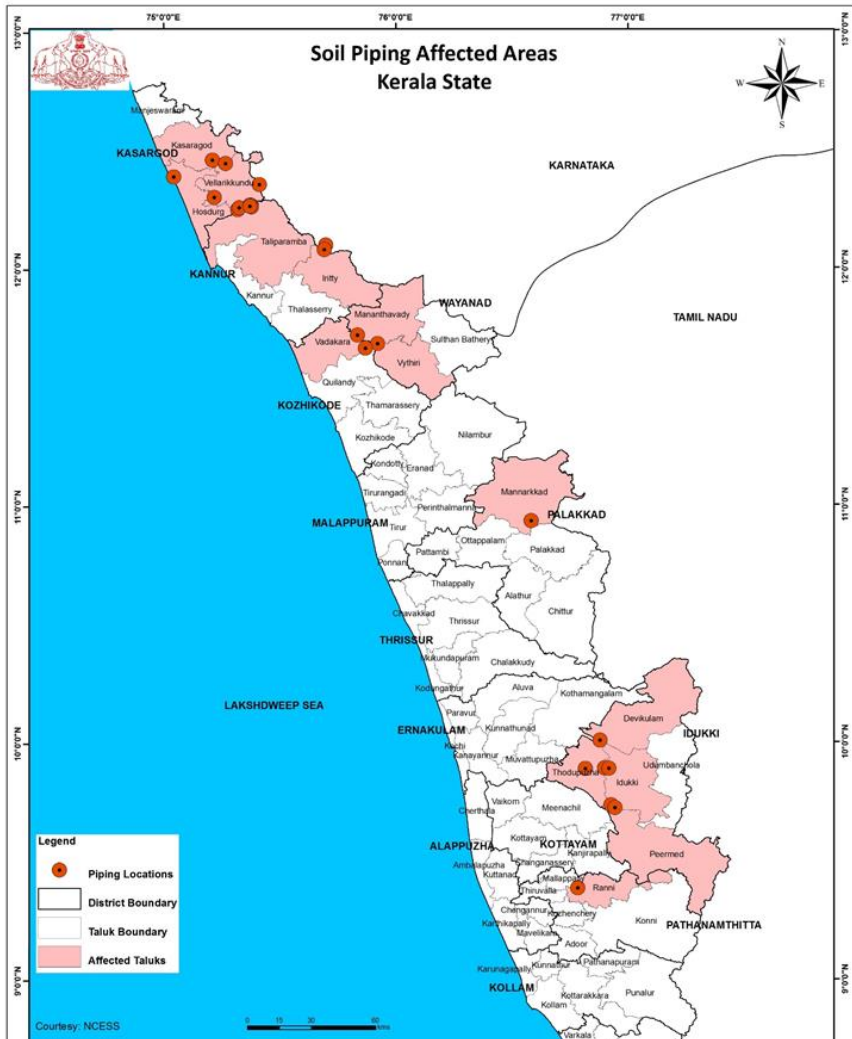

Courtesy: NCESS

0 10 20 30 Kilometers

REFERENCES

- ADPC. 2005. *Handbook on Design and Construction of Housing for Flood-Prone Rural Areas of Bangladesh*. Handbook, Dhaka: Asian Disaster Preparedness Center.
- FEMA. 2013. *Foundation Requirements and Recommendations for Elevated Houses*. New York: FEMA.
- GOI-UNDP. 2008. "Manual on Hazard Resistant Construction in India." Manual, Delhi.
- Gupta, Vikram. 2015. *Tackling the challenge of slope stabilization & landslide prevention*. Dehradun: Wadia Institute of Himalayan Geology.
- International Network for Bamboo and Rattan (INBAR). n.d. "Bamboo Constuction Techniques." Guide, New Delhi.
- Kerala State Emergency Operations Centre, National Centre for Earth Sciences Studies. 2016. *Studies on "The Soil Piping in the Highlands nad Foothills of Kerala to avoid the disaster"*. Project Report, New Delhi: National Disaster Management Authority.
- National Disaster Management Authority. 2010. *Maanagement of Urban Flooding*. Guidelines, New Delhi: National Disaster Management Authority.
- UN-Habitat. n.d. "Manual on Flood: Causes, effects and preparedness." Manuel.
- Verma, Radhika. n.d. "Mud Construction."

ANNEXURE

FEEDBACK



Training on Flood Resilient Construction Techniques

1. How did you find out about the training?

2. Did you participate in a Shelter Hub Training before?

Yes No Which one? _____

3. Did you learn something new during the training?

Yes No

4. Which elements of the training will be useful for you in your work?

5. Did you like the way of teaching?



6. Are the handouts helpful for you?



7. Was the on-site training helpful?



8. What would you like to learn more about?

9. What was good?

FLOOD RESISTANT CONSTRUCTION TECHNIQUE

UN HABITAT
FOR A BETTER URBAN FUTURE

United Nations
CENTRE FOR
URBAN RESILIENCE
AND PLANNING



Disaster Resistant Construction Practises

Roof / Slab

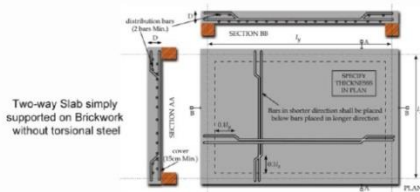
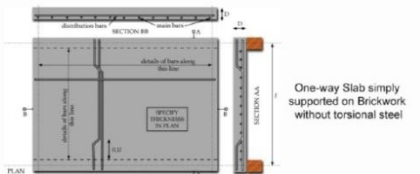

- RCC Slab at the support should be reinforced at both top and bottom

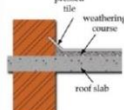

- Proper weathering course with pressed tile layer to protect RCC Slab

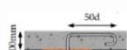
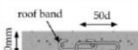

Foundation



- Straight Cut
- Sand compaction thickness < 150mm
- PCC thickness < 75mm



- Slightly Slanting cut
- Sand Compaction thickness > 150mm
- PCC thickness > 75mm

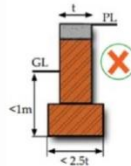

- Foundation width < 2½ times wall thickness
- Make a wall without foundation
- Use unbaked bricks in the foundation

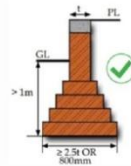

- Foundation width > 2½ times wall thickness or 0.6m, whichever is more
- Use baked bricks and stones
- Minimum depth = 1000 mm

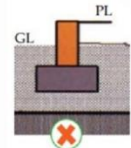

- Foundation on loose or soft soil

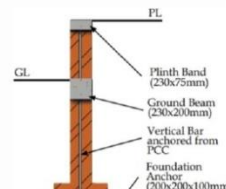

FLOOD RESISTANT CONSTRUCTION TECHNIQUE

Disaster Resistant Construction Practises

Walls



- Too High Walls



- Average wall height should be 2700 to 3000mm



- Too high walls
- Long unsupported walls



- Wall length < 8 times the thickness
- Addition of a buttress wall reduces L/H Ratio

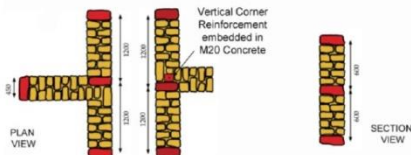

Through stone should be placed horizontally at a minimum spacing of 1200mm center-to-center

Through stone should be placed vertically at a minimum spacing of 600mm

Openings

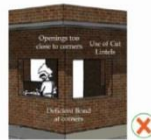

- Openings too close to corners



- Openings well away from the corners

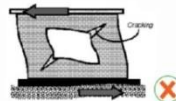

- Diagonal Cracking in building with no Corner Reinforcement

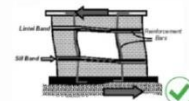

- No Cracks in Buildings with Vertical Reinforcement



- Too many unreinforced openings (minimum distance between unreinforced openings should be 600mm)

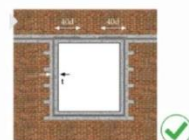

- Openings with Reinforced Band all around

Brick Masonry

FLOOD RESISTANT CONSTRUCTION TECHNIQUE



Disaster Resistant Construction Practises

Plinth / Bands

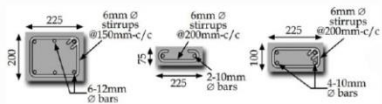
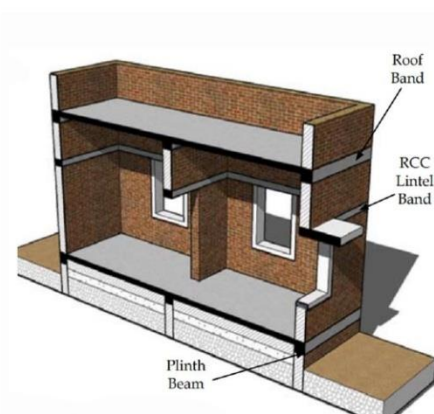

Beams / Columns

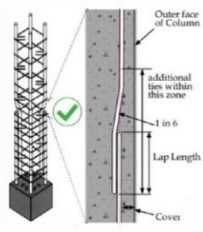

FLOOD RESISTANT CONSTRUCTION TECHNIQUE

UNO H A B I T A T
FOR A BETTER URBAN FUTURE



United Nations
CENTRE FOR
EMERGENCY
RESPONSE
COORDINATION

Central
Emergency
Response
Fund



Bamboo Construction Techniques

Foundation

The types of bamboo foundation identified are:

- Bamboo in direct ground contact
- Bamboo on rock or preformed concrete footings
- Bamboo incorporated into concrete footings
- Composite bamboo/concrete columns
- Bamboo reinforced concrete
- Bamboo piles

Bamboo in direct ground contact

For strength and stability, large diameter thick walled sections of bamboo with closely spaced nodes should be used.

Bamboo on rock or preformed concrete footings

It should be placed out of ground contact on footings of either rock or preformed concrete. Largest and stiffest sections of bamboo should be used.

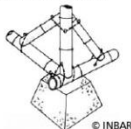

© INBAR

Bamboo incorporated concrete footings

This approach is to incorporate the bamboo directly into the concrete footing and can take the form of single posts or strip footings.



Bamboo reinforced concrete

Bamboo reinforced concrete slabs offer another solution, although this type of construction has its own specific problems.

Floor

Floor structure

Floors normally consist of bamboo beams fixed to strip footings or to foundation posts. The beams therefore run around the perimeter of the building. Where the beams are fixed to posts, careful attention to jointing is required. Beams and columns are generally around 100mm in diameter.

Small diameter culms:

Small diameter culms are tied or nailed directly to the joists

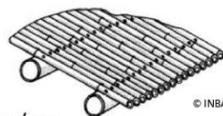

© INBAR

Split bamboo:

Bamboo culms are split along their length into strips several centimeters wide.

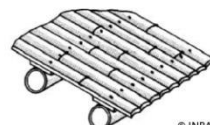

© INBAR

FLOOD RESISTANT CONSTRUCTION TECHNIQUE



Bamboo Construction Techniques

Walls

The most extensive use of bamboo in construction is for walls and partitions. The major elements of a bamboo wall (posts and beams) generally constitute part of the structural framework.

Whole or halved bamboo culms

The preferred orientation is vertical as this increases the shear resistance of the wall and is also better for drying after rain. Vertical members can be driven directly into the ground or fixed back to beams by tying with or without facing battens.

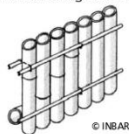

© INBAR

Split or flattened bamboo

Can be fixed vertically to intermediate bamboo members tied to or mortised into the posts, or fixed horizontally directly to the posts. Boards can be stretched or covered by wire mesh to provide a suitable surface for plastering.

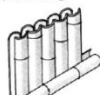

Roof

The simplest form of roof comprises a bamboo ridge purlin and eaves beams, supported on the perimeter posts.

Trusses offer a number of advantages over traditional forms of construction, including more economic and efficient use of materials, the ability to span larger distances, the use of shorter components (counteracting effects of bow, crook and taper) and the use of prefabrication.

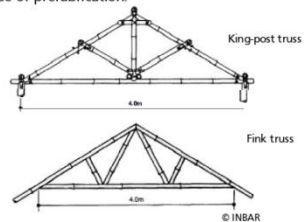

Bamboo tiles:

These can take the form of halved, internodal culm sections, fixed to battens and overlapped in a similar manner to the full length halved culms

Bamboo shingles:

Shingles, measuring 30-40mm wide x internodal length (400-600mm) are cut from green culms, 70mm or more in diameter and then air dried.

FLOOD RESISTANT CONSTRUCTION TECHNIQUES

UN HABITAT
FOR A BETTER URBAN FUTURE



United Nations
CENTRE FOR
DISASTER PREVENTION
AND RECOVERY

United Nations
CENTRE FOR
DISASTER PREVENTION
AND RECOVERY



Retrofitting Techniques for built-structures

Some common failures in Buildings during disaster



© IIT Roorkee

Failure of soft-stories. in RCC structure and its retrofitting

Soft-stories are most vulnerable part of the structure in multi stories most common failures is observed on soft-stories, there are several techniques of retrofitting of this type of buildings, like introduction of new column, shear wall, bracings etc. for detail refer following images:



Failure and collapse pattern

© TESRA

Retrofitting of Failure in Masonry Building

At the time of flood, in masonry buildings there are some common area which are most vulnerable for the damage. In above shown images cracks are developed



FLOOD RESISTANT CONSTRUCTION TECHNIQUE



Landslide Resistant Construction Techniques

Landslide Hazard - Kerala

In Kerala, landslides commonly occur in localized areas of the Western Ghats region where the slope is steep and the soil is over saturated as a result of prolonged rainfall. These events vary from events affecting a parcel of land to those larger ones with much causality.

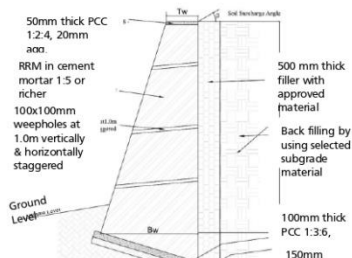

Gabion wall

Gabion Retaining walls are flexible structures which are very suitable in case of Tech 3 retaining structures for protection. It is also very effective for the protection near the water body, as the porosity of boulders will dissipate the wave energy effectively. Gabions are flexible in nature and can accommodate differential settlement very well.

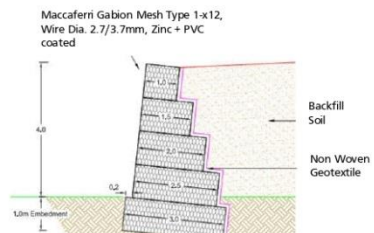

QUES

FLOOD RESISTANT CONSTRUCTION TECHNIQUE

UN HABITAT
FOR A BETTER URBAN FUTURE

United Nations
CERF
Central
Emergency
Response
Fund



Landslide Resistant Construction Techniques

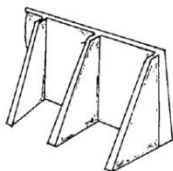

© Biswajit Bera

Concrete buttress wall or braced wall



Soil Piping- Kerala

The "Soil piping", also known as tunnel erosion is the subsurface erosion of soil by percolating waters to produce pipe-like conduits below ground especially in non-lithified earth materials. Soil piping or "tunnel erosion" is the formation of subsurface tunnels due to subsurface soil erosion. Piping is an insidious and enigmatic process involving the hydraulic removal of subsurface soil causing the formation of an underground passage.

Land subsidence causes many problems including:

- Changes in elevation and slope streams, canals and drains
- Damage to bridges, roads, railroads, storm drains, sanitary sewers, canals, and levees
- Damage to private and public buildings
- Failure of well casings from forces generated by compaction of fine-grained material in aquifer

HNIQUES

